

# Magnetic Sine Tables

Series AA-603

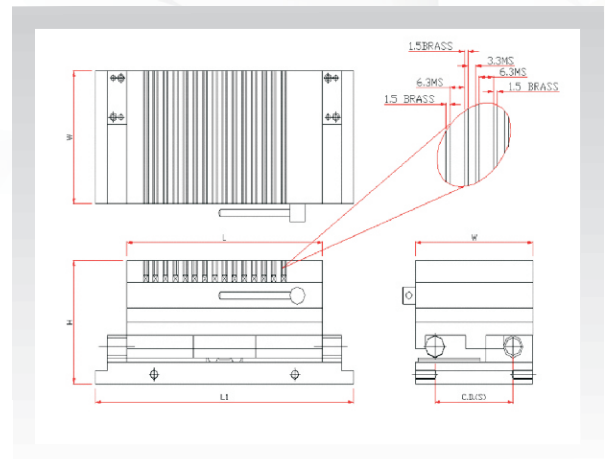
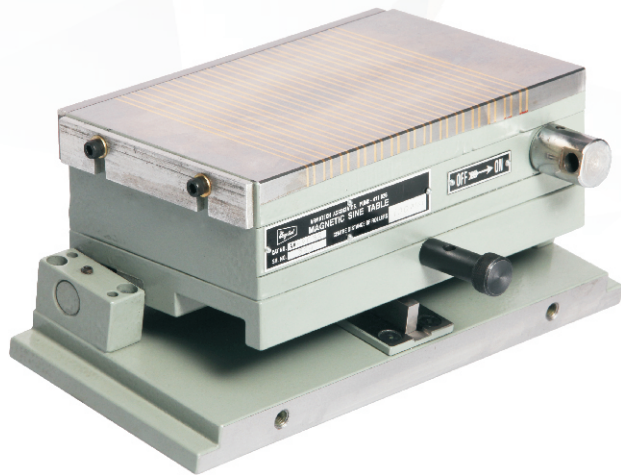

- Magnetic Sine tables are ideal for precision angle grinding & inspections.
- They are made from high quality steel & base plate contains hardened bits.
- An angle can be set to within  $\pm 5$  seconds of a degree.
- Firm hinge clamps reduce possibility of distortions.
- Flatness 0.005mm per 100 mm. Center distance of the roller is within 0.005 mm.
- Fine pitch chuck of 9.9mm with laminated brass pole is provided for rigid clamping of small , medium & large components.
- Suitable for angle range from 0-45 degree.

## Specifications:

Sr. No.	Cat. No.	Size in mm L X W X H	C. D. of Roller (mm)	Bottom Plate Length (L1)
1	AA-6031	150 X 120 X 135	70	230
2	AA-6032	250 X 150 X 135	100	330
3	AA-6033	300 X 150 X 140	100	380
4	AA-6034	450 X 150 X 140	100	530
5	AA-6035	400 X 200 X 140	150	480